Version
01.00January
2006

UHF Transmitter Family R&S® NH 7000C/NV 7000

Liquid-cooled transmitters for analog (combined) and digital TV (DVB-T/H or ATSC)

- ◆ Combined amplification of vision and sound for analog TV
- ◆ Easy conversion from analog to digital by using identical final stage design
- ◆ Frequency range 470 MHz to 860 MHz
- ◆ Advanced LDMOS¹⁾ technology for power amplifiers
- ◆ Digital precorrection
- ◆ Liquid cooling system
- ◆ High redundancy
- ◆ Highly compact design for minimum space requirements
- ◆ Cost-effective installation
- ◆ All standby concepts possible (single transmitter, active or passive output-stage standby, exciter standby)

¹⁾ LDMOS = lateral diffused metal oxide silicon.

A new generation of transmitters

At a glance

The TV Transmitter Family R&S® NH 7000C/ NV 7000 is a new generation of liquid-cooled UHF transmitters for analog (combined) and digital TV (**DVB-T or ATSC**). They consist of the following main components:

- ◆ Exciter
- ◆ Power amplifiers incl. power supply
- ◆ Transmitter rack

The UHF transmitters are available for analog TV (combined) with powers of 3.5 kW to 20 kW and for DVB-T with powers of 800 W to 6.4 kW or ATSC with 1.3 kW to 10.4 kW (higher power ratings on request). Each amplifier has its own power supply that is integrated into the amplifier module and thus cooled by the liquid cooling system.

The amplifier module is self-engaging and can be exchanged during operation without any loss of liquid from the closed cooling system and without impairing the operation of the other modules.

The power supplies are fed with AC supply voltage, i.e. no auxiliary voltage supplies are required, which improves the availability of the transmitters. Parts exclusively made of stainless steel, aluminum or plastic are used for the cooling system in the transmitter rack.

All transmitters can be equipped with a second exciter and the associated automatic switchover unit, the two units being integrated into the transmitter rack.

Transmitter rack

The transmitters with a maximum output power of 10 kW for analog TV, 3.4 kW for DVB-T or 5.4 kW for ATSC are accommodated in a rack 630 mm in width. This means that space requirements are at a minimum since components such as the harmonics filter and bandpass filter (up to 5 kW for analog (combined) or 1.7 kW for digital TV) are also accommodated in the transmitter rack. The bandpass filter for higher output powers is installed outside the transmitter rack. To obtain higher power, further racks fitted with the necessary amplifier plug-ins and couplers are required.

The connectors for modulation lines (VF, AF or TS), for example, as well as the remote control interface etc are located on the top of the transmitter rack.

The connectors for the cooling system can be either on the top or bottom of the rack. The tubing used throughout the cooling system is of uniform cross-section to avoid different flow rates and thus blocking.



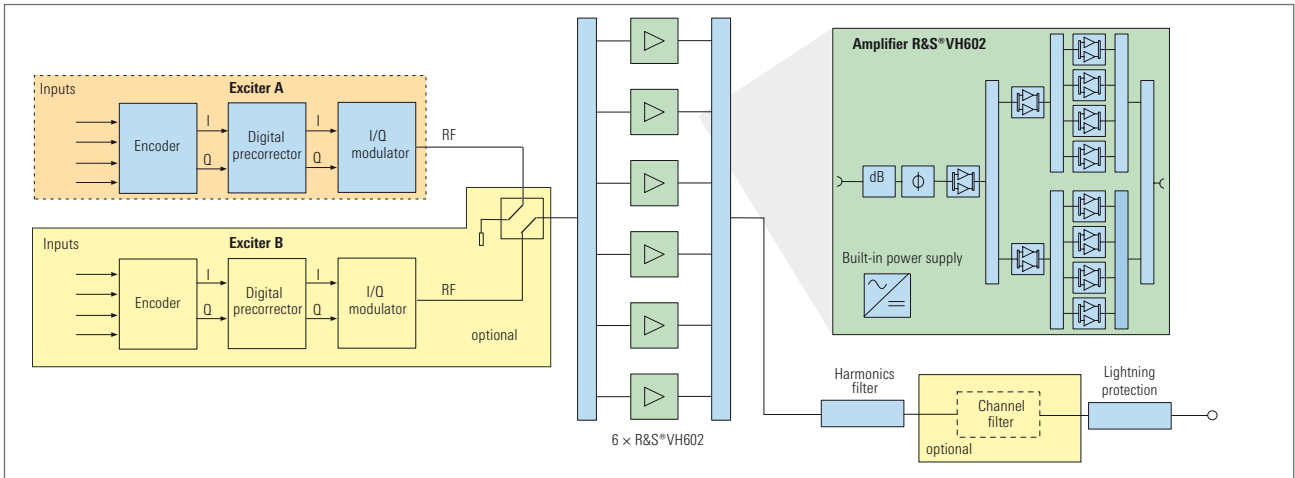

Block diagram of the 7.5 kW analog (combined) or equivalent digital 2.5 kW (DVB-T)/4.1 kW (ATSC) transmitter



Exciter

The new exciter comprises the following modules:

- ◆ Encoder for analog (combined) TV, DVB-T or ATSC
- ◆ Digital precorrector
- ◆ Modulator
- ◆ Synthesizer
- ◆ Controller
- ◆ Control unit
- ◆ Motherboard
- ◆ Power supply

A NICAM module and a GPS module can be installed as options.

Power amplifiers and final stage

Owing to advanced LDMOS technology, the power amplifiers feature high linearity, excellent efficiency and compact design. The power supply is integrated into the amplifier module, which is an enclosed unit. There is practically no heat dissipated in the rack since the air circulates within the amplifier module by means of a radial fan and the residual heat is conveyed to the cooling system via a heat exchanger.

Protective circuits against reflection, overtemperature etc are provided. The junction temperature of the transistors is around 120 °C under normal operating conditions and at an ambient temperature of 25 °C.

The design of the final stage is identical for analog combined and digital amplification. Therefore, no modification of the power path is required in the event of a future conversion from analog to digital television.

Since the modules are very compact, two complete exciters including the associated automatic switchover unit can be accommodated in a 19" main-frame of seven height units. Each exciter has its own power supply so that full redundancy is ensured. The fully digital precorrection can be reproduced to the full. No adjustments are required after module replacement.

The transmitter is operated with the aid of PC software under Windows or via a display integrated into the control unit.

Analog (combined) mode

The encoder for analog TV first digitizes the video and audio input signals. The processing of these signals in line with the associated TV or color coding standard is digital which provides high stability and easy correction.

The encoder uses digital filters to convert the processed video signal and the sound subcarriers separately for signal display with inphase and quadrature signal.

DVB-T/-H mode

The encoder for DVB-T (DVB-H optional) is integrated in a single module. It has four physical ASI interfaces that in pairs form a complete processing path (input interface, FEC and delay). The encoder is thus prepared for hierarchical modulation. For non-hierarchical coding, the two paths can be selected as a main and a stand-by path.

The encoder can be used both in multi-frequency networks and single-frequency networks. For single-frequency networks, a GPS receiver is integrated.

ATSC mode

The ATSC encoder module comprises data randomizer, Reed-Solomon encoder, data interleaver, Trellis encoder, MUX and pilot insertion. Channel coding and modulation are in line with Doc. ATSC-A53.

Equalizer

All versions of the encoder transfer the digital inphase and quadrature signals with a resolution of 12 bit to the digital precorrector. The precorrector is divided into two sections:

- ◆ The group-delay equalizer can compensate the group delay that occurs, for example, in power filters
- ◆ The linearity precorrector can precorrect the instantaneous signal amplitude and phase

Since precorrection is digital, the reproducibility is 100 % even if modules are replaced.

Central control unit

The central control unit accommodated in the exciter rack controls and monitors the entire transmitter. This central control unit enables the user to access the parameters of the entire system, in particular those of the integrated encoders, via the control panel. In this way, only one remote control interface is required to monitor all functional units of the transmitter.

Cooling system

The standard cooling system (as an external unit outside the transmitter rack) includes a pumping set for each transmitter rack. The pumping set consists of two pumps operating in series for full redundancy, a control unit and a mixer. A cooler is installed outside the transmitter room for each pumping set. The cooler is fitted with two fans operating in active standby for redundancy. The cooling agent used is AntifrogenN.

Block diagram of the cooling system

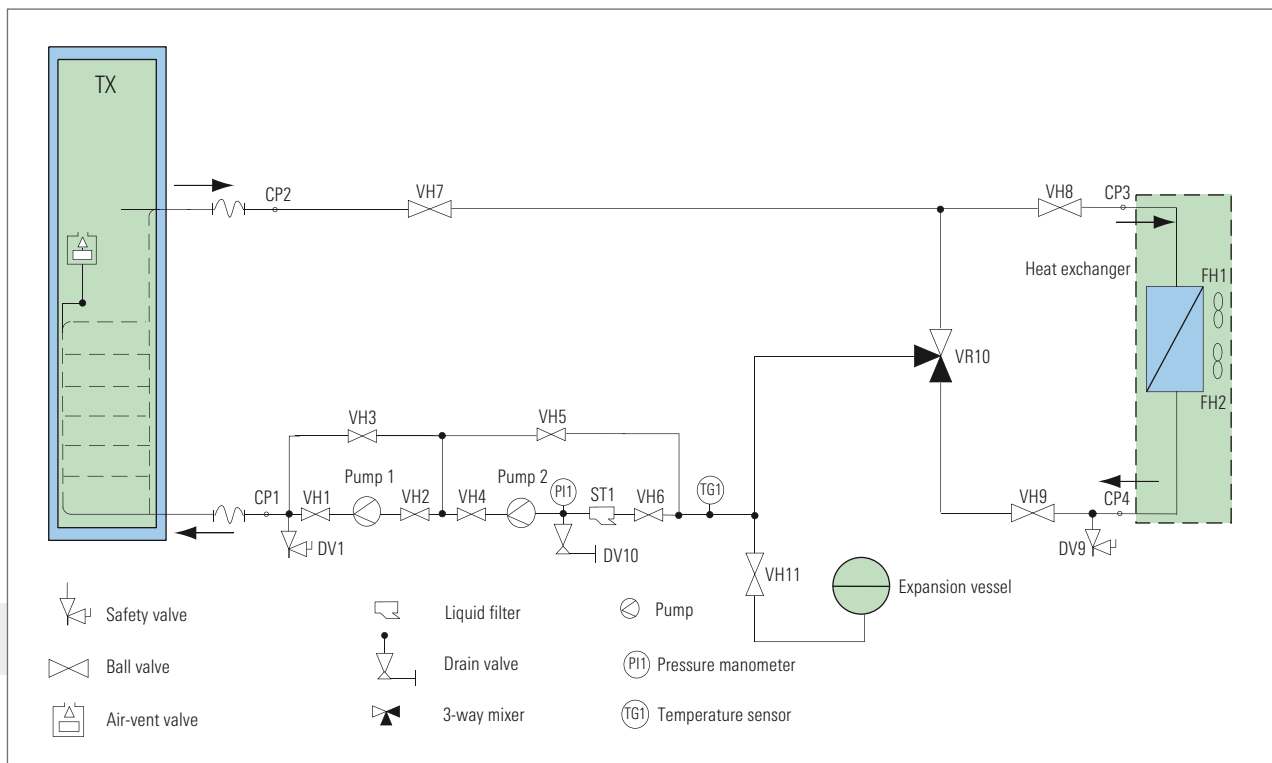

Specifications

Common data for R&S®NH 7000C/NV 7000

Frequency range	470 MHz to 860 MHz
Power supply	230 V/400 V \pm 15 %, 50 (60) Hz \pm 2 %
Max. installation altitude	2000 m above sea level (>2000 m on request)
Operating temperature range	+1 °C to +45 °C
Outside temperature range	-30 °C to +50 °C
Permissible relative air humidity	95 %
Inputs	
Analog TV (combined)	2 \times video (BNC, 75 Ω), 2 \times sound (XLR, 3-contact)
DVB-T/H	2 \times ASI (in pairs, prepared for hierar- chical modulation)
ATSC	2 \times SMPTE-310 (BNC, 75 Ω)
Interfaces	
RS-232-C	at the front, operation of transmit- ter by means of graphical user inter- face (GUI) from PC, D-Sub, female, 9-contact
RS-485	for remote control of transmitter, at transmitter top, D-Sub, female, 9-contact
RS-232-C	for remote control of transmitter, at transmitter top, D-Sub, female, 9-contact (connection of Hayes- compatible modem)

Optional	parallel remote control interface, floating, for messages and com- mands; SNMP interface and/or TCP/IP web server
Analog TV	
TV standards	B, G, D, K, M, N, I
Color transmission	PAL, NTSC, SECAM
Sound transmission	dual-sound coding to IRT or FM single sound and NICAM 728 (-13 dB / -20 dB) or FM single sound (-10 dB)
DVB-T/H	coding and modulation in line with EN 300744/EN 302304 (optional)
IFFT mode	2k, 4k and 8k
Useful symbol period	224 μ s (2k), 448 μ s (4k) or 896 μ s (8k)
Modulation	QPSK, 16QAM or 64QAM
Guard interval	1/4, 1/8, 1/16 or 1/32 of useful symbol period
Inner code rate	1/2, 2/3, 3/4, 5/6 or 7/8
Hierarchical coding	on request
ATSC	in line with Doc. A53/1995
Modulation	8VSB
Symbol rate	10.76 MHz
Data rate	19.39 Mbit/s
Trellis coding	2/3
Reed-Solomon encoder	207/187/10

Specifications of R&S®NH 7000C (analog TV, combined)

	R&S®NH 7030C	R&S®NH 7040C	R&S®NH 7060C	R&S®NH 7080C	R&S®NH 7120C	R&S®NH 7160C
RF output power ¹⁾ (analog TV, combined)	3.5 kW	5 kW	7.5 kW	10 kW	15 kW	20 kW
Number of vision amplifiers	3	4	6	8	12	16
Cooling	liquid-cooled					
Dimensions in mm (W \times H \times D)	630 \times 2167 \times 1200				1260 \times 2167 \times 1200	
RF connectors	EIA 1 5/8"			EIA 3 1/8"		
Reference frequency	1 MHz, 5 MHz or 10 MHz, 0.1 V to 5 V (V_{pp}) or TTL, BNC					
Bandwidth	6 MHz, 7 MHz and 8 MHz					

Specifications of R&S®NV 7000 (DVB-T/ATSC)

	R&S®NV 7080	R&S®NV 7130	R&S®NV 7170	R&S®NV 7250	R&S®NV 7340	R&S®NV 7500	R&S®NV 7640
RF output power ¹⁾ (DVB-T)	800 W	1.3 kW	1.7 kW	2.5 kW	3.4 kW	5 kW	6.4 kW
RF output power ¹⁾ (ATSC)	1.3 kW	2.0 kW	2.7 kW	4.1 kW	5.4 kW	7.8 kW	10.4 kW
Number of amplifiers	2	3	4	6	8	12	16
Cooling	liquid-cooled						
Dimensions in mm (W \times H \times D)	630 \times 2167 \times 1200					1260 \times 2167 \times 1200	
RF connectors	EIA 1 5/8"				EIA 3 1/8"		
Reference frequency	1 MHz, 5 MHz or 10 MHz, 0.1 V to 5 V (V_{pp}) or TTL, BNC						
Bandwidth	7 MHz and 8 MHz for DVB-T; 6 MHz for ATSC						
Reference pulse	1 Hz, TTL, BNC						

¹⁾ Other power ratings on request.

More information at
www.rohde-schwarz.com
(search terms: NH7000C, NV7000)



ROHDE & SCHWARZ

www.rohde-schwarz.com

Europe: +49 1805 12 4242, customersupport@rohde-schwarz.com
USA and Canada: 1-888-837-8772, customer.support@rsa.rohde-schwarz.com
Asia: +65 65130488, customersupport.asia@rohde-schwarz.com